

MF48 SERIES

Mixer Cartridge Seal

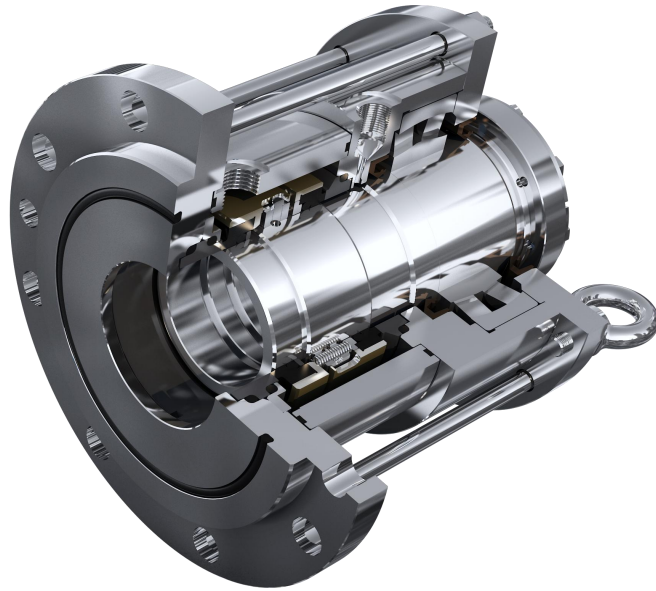

- Unbalance Design
- Independent of direction of rotation
- Cartridge Unit
- Connections according to DIN

Shanghai Newworld Fluid Machinery Co.,Ltd

Web: www.newworld-cn.com

Email: sales@newworld-cn.com

Tel.: +86 21 60255286

Factory Add.: No.11 Xinghuo Road, Qianzhou Supporting Area,
Huishan District, Wuxi City, Jiangsu Province, China

International sales office:

Tel: +86 21 60255286

Add :Room 501 No 1198 Defu Road Jiading District Shanghai China

MF48 SERIES

All quality mechanical seals should fit properly and be “leak-free” in operation. Fluid containment is achieved by precision lapping rotary & stationary faces and keeping the faces in contact. To guarantee these basic requirements all our mechanical seals are hydrostatically pressure tested to ensure they fit the shaft and are leak free, before leaving the factory.

Design Model Description

- ▼ Corrosion Resistance
- ▼ Better and even heat transferring property
- ▼ Cartridge Structure
- ▼ To DIN28136/28141/28154

Application

Applicable for Rotating Shaft Equipments, i.e.: Agitator

Applied Fluids: Dirty Oil, Crude Oil with Water, and Fluid Contains Solid Particles, Sewage, Services in Chemical Industrial Materials.

Operating Limits

- ▼ Temperature: -10°C to 200°C
- ▼ Pressure: Up to 0.6Mpa
- ▼ Speed: Up to 2m/s

Type MF48/MF48L Seal

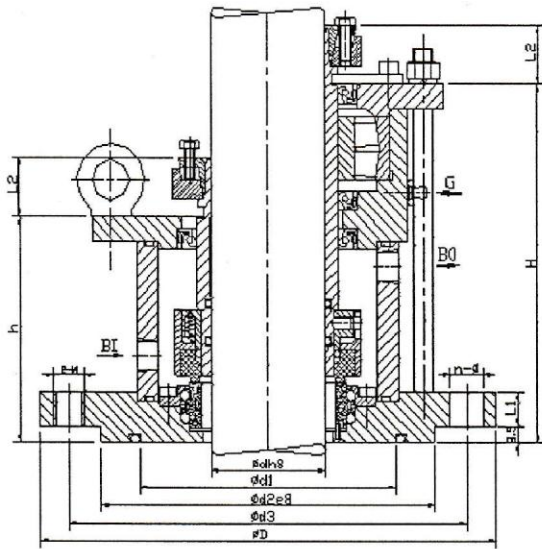

Type MF48D/MF48LD Seal

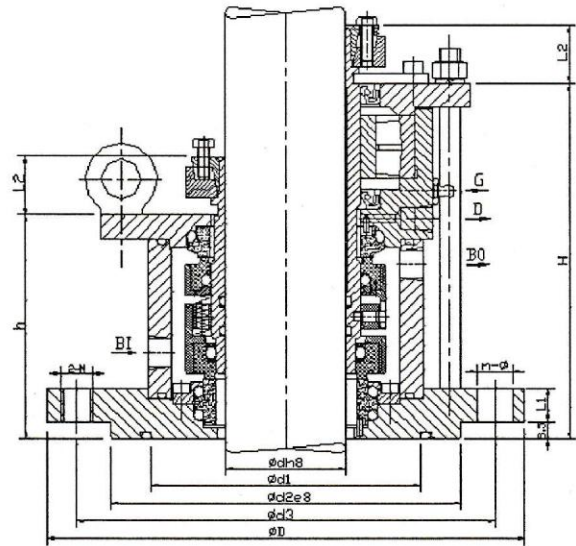

Material Selection Table

Description	Material	MF48	MF48L	MF48D	MF48LD
Faces	High Grade Carbon	○	○	○	○
	Resin Carbon	○	○	○	○
	Antimony Carbon	●	●	●	●
	Silicon Carbide	○	○	○	○
	Tungsten Carbide	○	○	○	○
Spring	CrNi-Steel	○	○	○	○
	CrNiMo-Steel	●	●	●	●
	Hasterlloy-C276	○	○	○	○
Secondary Seal	Fluorocarbon Rubber	●	●	●	●
	Ethylene Propylene Rubber	○	○	○	○
	Butyl Rubber	○	○	○	○
	Filled PTFE	○	○	○	○
Other	CrNi-Steel	●	●	●	●
	CrNiMo-Steel	○	○	○	○

1. ● Preferred Material
2. ○ Optional Material
3. Please contact us for special design inquiries.

MF48 SERIES

Installation Dimensions for MF48

(mm)

d	d1	d2	d3	D	h	H	L1	L2	n-Ø	2-M	BI/BO
40	90	110	145	175	110	162	15	33	4-18	M16	3/8NPT
50	135	176	210	240	110	174	17	33	8-18	M16	3/8NPT
60	135	176	210	240	115	178	17	33	8-18	M16	3/8NPT
70	135	176	210	240	115	189	17	34	8-18	M16	3/8NPT
80	155	204	240	275	130	217	20	40	8-22	M20	1/2NPT
90	190	234	270	305	135	217	20	40	8-22	M20	1/2NPT
100	190	234	270	305	135	218	20	40	8-22	M20	1/2NPT
110	215	260	295	330	135	227	20	46	8-22	M20	1/2NPT
125	215	260	295	330	140	237	20	46	8-22	M20	1/2NPT
140	250	313	350	395	140	244	20	46	12-22	M20	1/2NPT
160	265	313	350	395	155	252	25	46	12-22	M20	1/2NPT
180	310	364	400	445	160	263	25	46	12-22	M20	1/2NPT
200	310	364	400	445	175	271	25	46	12-22	M20	1/2NPT
220	340	422	460	505	175	271	25	46	16-22	M20	1/2NPT